

# TRENCHER

## User Manual

---

### SAFETY AND OPERATION INSTRUCTIONS

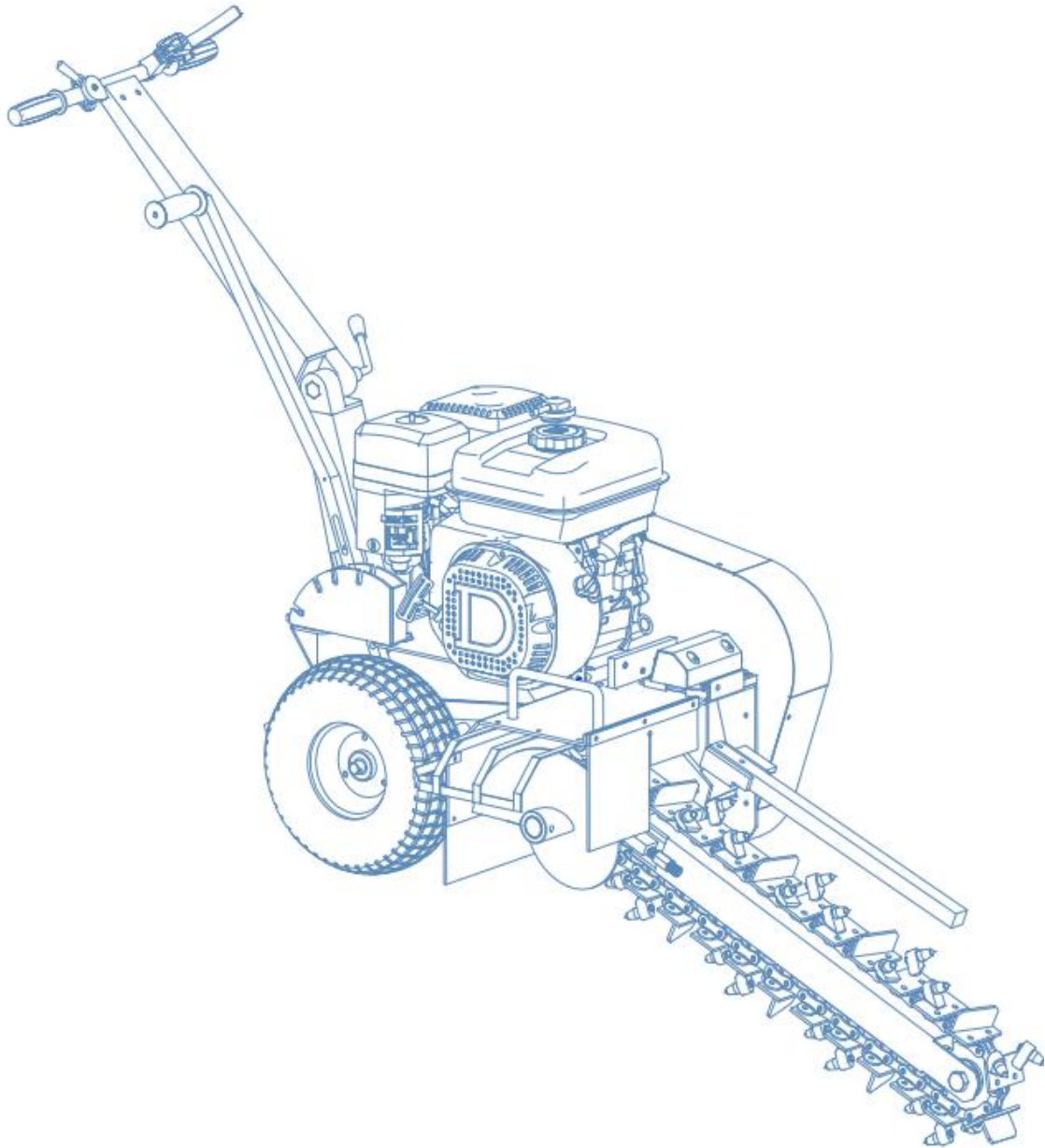

---

---

**IMPORTANT:** Read safety rules and instructions carefully before operating

**equipment.**

## Table of Contents

PART I: General Safety Rules .....	2
PART II: Familiar with Your Trencher .....	8
PART III: Operating the Trencher .....	11
PART IV: Maintaining Your Trencher .....	17
PART V: Troubleshooting and Parts List .....	19

### Conventions used in this manual

---

#### **WARNING**

This indicates a hazardous situation, which, if not avoided, could result in death or serious injury.

---

#### **CAUTION**

This indicates a hazardous situation, which, if not avoided, could result in minor or moderate injury.

---

#### **NOTICE**

This information is important in proper using of your machine. Failure to follow this instruction could result in damage to your machine or property.

---

### Additional Information and Potential Changes

We reserve the right to discontinue, change, and improve its products at any time without notice or obligation to the purchaser. The descriptions and specifications contained in this manual were in effect at printing. Equipment described within this manual may be optional. Some illustrations may not be applicable to your machine.

# PART I: General Safety Rules

## Safety Labels May Be Found on Your Unit

**! WARNING AND SAFTY INSTRUCTIONS**

### OPERATOR SAFETY

- Always wear the proper clothing and protective gear. Eye and ear protection, hard hat, boots, gloves and dust masks are that may be required.
- Keep hair, fingers, and all other body parts away from openings and moving parts. Always wear, long pants, boots, and gloves. Secure hair so it is above shoulder length.
- Do not operate trencher indoors. outdoor use only.
- Do not operate trencher when tired, ill, or under the influence of alcohol, drugs, or medication.
- Always assume the digging location contains underground utilities. Contact appropriate utility company to determine where electrical cables, gas lines, water lines, etc. are buried before operation.
- Always use extreme caution while operating tool. Be sure of your footing and physical capabilities.

### TOOL SAFETY

- Inspect entire trencher before each use. Replace damaged or worn parts.
- Check for fuel leaks and make sure all fasteners are in place and securely fastened.
- Replace digging blades that are severely worn. Be sure the digging chain and engine is not moving.

### MAINTENANCE SAFETY

- Maintain according to recommended procedures included in this manual.
- Disconnect the spark plug wire before performing maintenance.
- Stop engine before removing fuel cap.
- Use only genuine replacement parts of the engine manufacturer.

### FUEL SAFETY

- Refuel outdoors and where no sparks and flames.
- Store fuel in a container approved for gasoline.
- Do not smoke or allow smoking near fuel or the trencher or while using the trencher.
- Clean up all fuel spills before starting engine.
- Move at least 10 feet away from fueling site before starting engine.
- Stop engine before removing fuel cap.

### DIGGING SAFETY

- Be sure that the area is clear of potential hazards, such as pipes, rocks or other materials that could possibly entangle itself around the digging chain or cause unstable footing before using the trencher.
- Keep others bystanders and helpers outside a 15 foot hazard zone from the trencher.
- Hold the trencher handle firmly with both hands.
- Keep all your body and clothing away from the digging chain, auger and other moving parts.
- Inspect the digging site. Soil, job specifications and operator experience may dictate that a different trencher or method be used to do the job.
- Do not leave trenches open or unmarked.

### TRANSPORTATION AND STORING

- Always shut off the fuel valve and engine.
- Always allow the engine to cool.
- Store trencher and fuel where fuel vapors cannot reach sources of combustion like, water heaters, electric motors, switches, furnaces, etc.
- Always secure this trencher with tie downs or similar restraints when transporting.
- The trencher shall be stored in a manner that prevents it from falling, rolling or tipping over.



**! WARNING**

- **KEEP CLEAR**

Foot Crush Zone  
May pinch your foot,  
cause serious injury.  
Keep Back!!



**! WARNING**

- **KEEP BACK**

Rotating shaft can  
cause severe injury.  
Keep arms, legs, hair  
and loose clothing away

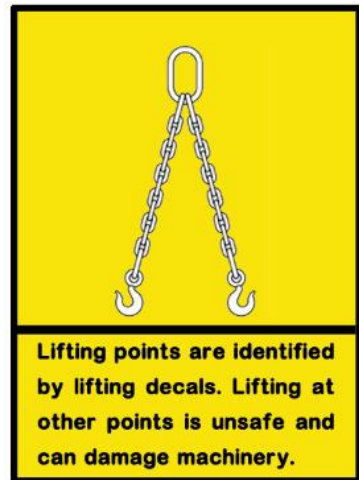

	<b>⚠ DANGER</b>
	<b>● KEEP CLEAR</b> Moving Digging Teeth will kill you or cut off arm or leg. Stay Away!

	<b>⚠ WARNING</b>
	Always wear Hearing protecting when operating the trencher

---

## **⚠ WARNING**

This machine can cause serious injury to the operator and bystanders. The warning and safety instructions in this manual must be followed to provide reasonable safety and efficiency in using and storing. The operator is responsible for following the warnings and instructions in this manual and the trencher. Read the entire Operator's Manual before using this trencher! Restrict the use of this trencher to persons who read, understand, and follow the warnings and instructions in this manual and on the trencher. If you have not read and understand the warnings and instructions in this manual and on the trencher, you are not qualified to operate this trencher! Become familiar with the operation and service recommendations to ensure the best performance of your machine.

---

## **Propose**

---

## **⚠ CAUTION**

This machine is designed solely to dig trench and must not be used for any other purpose.

It should only be used by trained operators who are familiar with the content of this manual. It is potentially hazardous to fit or use any parts other than your dealer parts. We disclaim all liability for the consequences of such use, which in addition voids the machine warranty.

---

## Before using the Trencher

---

### NOTICE

- A. Operators must be fully trained before using this machine.
  - B. User Manual is read and understood.
  - C. Blades are in good condition and secure. All blades are sharpened or replaced in sets.
  - D. All fasteners are checked for tightness.
- 

## When using the Trencher

---

### WARNING

- A. Maintain strict discipline at all times and service machine at specified periods.
  - B. Keep body parts, foreign objects and clothing clear of rotating auger and digging chain.
  - C. Coming into contact with buried utilities while digging can cause severe injuries or DEATH.
  - D. Contact appropriate utility representatives to determine if/where electrical cables, gas lines, water lines, etc. are buried BEFORE operation.
  - E. DO NOT operate the machine whilst under the influence of alcohol or drugs.
- 

## Protecting Yourself and Those around You

---

### WARNING

This is a high-powered machine, with moving parts operating with high energy. You must operate the machine safely. Unsafe operation can create a number of hazards for you, as well as anyone else in the nearby area. Always take the following precautions when using this machine:

- A. Keep in mind that the operator or user is responsible for accidents or hazards occurring to other people, their property, and themselves.
  - B. Always wear protective goggles or safety glasses with side shields while using the Trencher to protect your eyes from possible thrown debris.
  - C. Avoid wearing loose clothing or jewelry, which can catch on moving parts.
  - D. Wear shoes with non-slip treads when using your Trencher. If you have safety shoes, we recommend wearing them. Do not use the machine while barefoot or wearing open sandals.
  - E. Keep bystanders at least 50 feet away from your work area at all times. Stop the engine when another person or pet approaches.
- 

## Safety for Children and Pets

---

## **WARNING**

Tragic accidents can occur if the operator is not alert to the presence of children and pets. Children are often attracted to the machine and the digging activity. Never assume that children will remain where you last saw them. Always follow these precautions:

- A. Keep children and pets at least 50 feet from the working area and ensure they are under the watchful care of a responsible adult.
  - B. Be alert and turn the machine off if children or pets enter the work area.
  - C. Never allow children to operate the Trencher.
- 

## **Safety with Gasoline - Powered Machines**

---

## **WARNING**

Gasoline is a highly flammable liquid. Gasoline also gives off flammable vapor that can be easily ignited and cause a fire or explosion. Never overlook the hazards of gasoline. Always follow these precautions:

- A. Never run the engine in an enclosed area or without proper ventilation as the exhaust from the engine contains carbon monoxide, which is an odorless, tasteless, and a deadly poisonous gas.
- B. Store all fuel and oil in containers specifically designed and approved for this purpose and keep away from heat and open flame, and out of the reach of children.
- C. Replace rubber fuel lines and grommets when worn or damaged and after 5 years of use.
- D. Fill the gasoline tank outdoors with the engine off and allow the engine to cool completely. Don't handle gasoline if you or anyone nearby is smoking, or if you're near anything that could cause it to ignite or explode. Reinstall the fuel tank cap and fuel container cap securely.
- E. If you spill gasoline, do not attempt to start the engine. Move the machine away from the area of the spill and avoid creating any source of ignition until the gas vapors have dissipated. Wipe up any spilled fuel to prevent a fire hazard and properly dispose of the waste.
- F. Allow the engine to cool completely before storing in any enclosure. Never store a machine that has gas in the tank, or a fuel container, near an open flame or spark such as a water heater, space heater, clothes dryer or furnace.
- G. Never make adjustments or repairs with the engine running. Shut down the engine, disconnect the spark plug wire, keeping it away from the spark plug to prevent accidental starting, wait 5 minutes before making adjustments or repairs.
- H. Never tamper with the engine's governor setting. The governor controls the maximum safe operation speed and protects the engine. Over-speeding the engine is dangerous and will cause damage to the engine and to the other

moving parts of the machine. If required, see your authorized dealer for engine governor adjustments.

- I. Keep combustible substances away from the engine when it is hot.
  - J. Never cover the machine while the muffler is still hot.
  - K. Do not operate the engine with the air cleaner or the carburetor air intake cover removed. Removal of such parts could create a fire hazard. Do not use flammable solutions to clean the air filter.
  - L. The muffler and engine become very hot and can cause a severe burn; do not touch.
- 

## General Safety

---

### **WARNING**

Operating this Trencher safely is necessary to prevent or minimize the risk of death or serious injury. Unsafe operation can create a number of hazards for you. Always take the following precautions when operating:

- A. Your Trencher is a powerful tool, not a plaything. Exercise extreme caution at all times. The machine is designed to dig trench. Do not use it for any other purpose.
  - B. Know how to stop the Trencher quickly.
  - C. Exercise caution to avoid slipping or falling.
  - D. See manufacturer's instructions for proper operation and installation of accessories.
  - E. Never use the machine without ensuring that all guards and shields are in place.
  - F. Never, under any conditions, remove, bend, cut, fit, weld, or otherwise alter standard parts on the Trencher. This includes all shields and guards. Modifications to your machine could cause personal injuries and property damage and will invalidate your warranty.
  - G. If the machine start to make an unusual noise or vibrate, shut down the engine, disconnect the spark plug wire, keeping it away from the spark plug to prevent accidental starting, wait 5 minutes for engine to cool down, then inspect for damage. Vibration is generally a warning of trouble. Check damaged parts and clean, repair and/or replace as necessary.
  - H. Never tamper with safety devices. Check their proper operation regularly.
  - I. Before performing any maintenance or inspection procedure, shut down the engine, disconnect the spark plug wire keeping it away from the spark plug to prevent accidental starting, wait 5 minutes for machine to cool down.
  - J. Never allow people who are unfamiliar with these instructions to use the Trencher. Allow only responsible individuals who are familiar with these rules of safe operation to use your machine.
  - K. Never overload or attempt to dig trenches beyond the manufacturer's recommendation. It could result in personal injury or damage to the machine.
  - L. While using, don't hurry or take things for granted. When in doubt about the
-

equipment or your surroundings stop the machine and take time to look things over.

- M. Never operate the machine when under the influence of alcohol, drugs, or medication.
  - N. Use the machine only in daylight.
  - O. Stay alert for hidden hazards or traffic.
  - P. Keep all nuts and bolts tight and keep the equipment in good operating condition.
- 

## **A Note to All Users**

List of warnings and cautions cannot be all-inclusive. If situations occur that are not covered by this manual, the operator must apply common sense and operate this TRENCHER in a safe manner. Contact the dealers for assistance in your area.

## PART II: Familiar with Your Trencher

---

---

It may be helpful to familiarize yourself with the controls and features of the Trencher. If you have any question, please contact the dealers in your area.

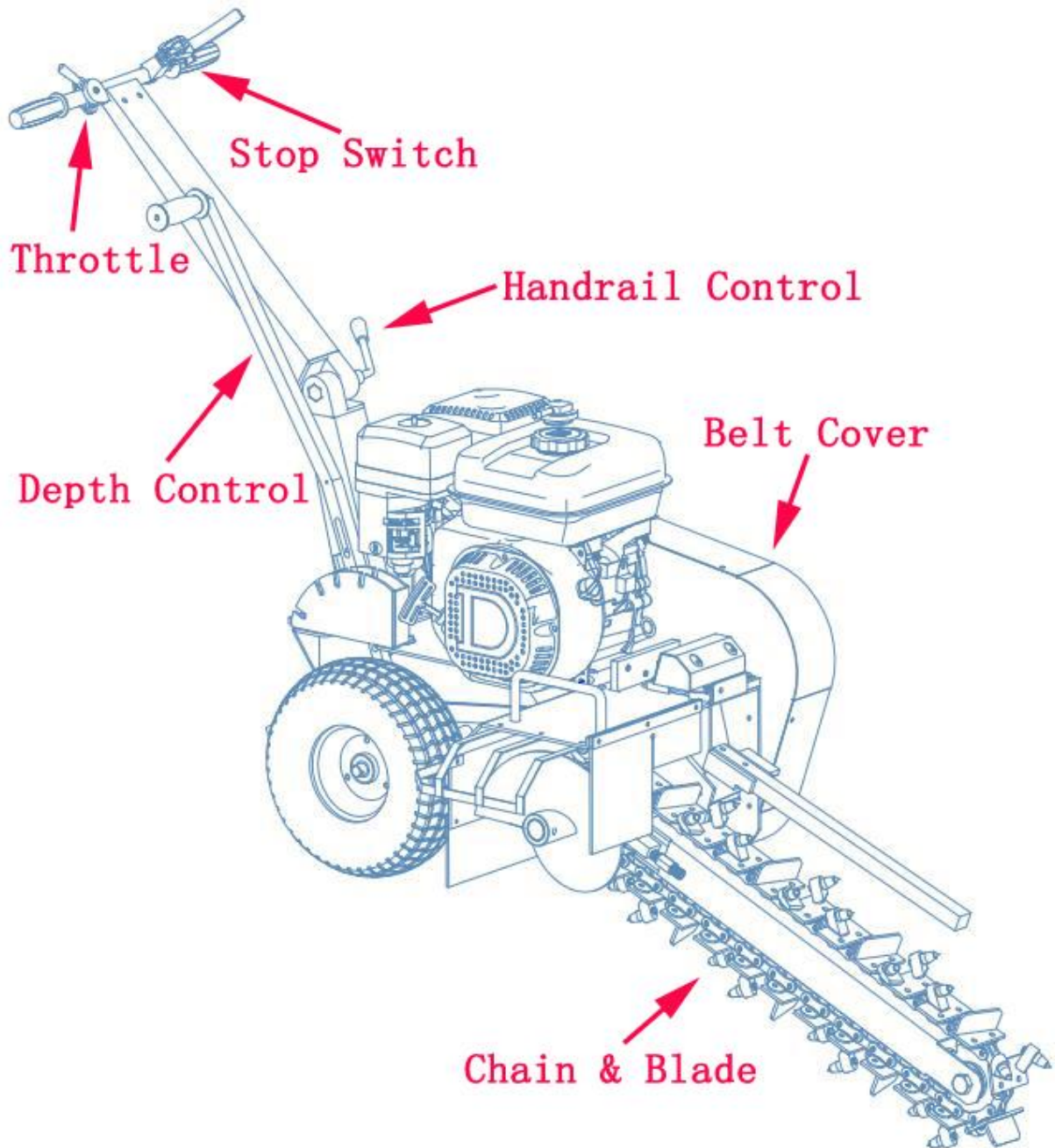

## TECHNICAL SPECIFICATIONS

<b>Model</b>	<b>DR-TR-15</b>
<b>Engine</b>	<b>13/13.5/15HP      four strokes</b>
<b>Power</b>	<b>Gasoline/petrol</b>
<b>Trench Capacity</b>	<b>60m/hour</b>
<b>Trench Width</b>	<b>100mm</b>
<b>Trench Depth</b>	<b>200,400,600mm</b>
<b>Blade</b>	<b>27 carbide alloy blades</b>
<b>Chain Length</b>	<b>2000mm</b>
<b>Chain Speed(Max)</b>	<b>550m/min</b>
<b>Tire</b>	<b>145/7.0-6</b>
<b>Overall Height</b>	<b>1100mm</b>
<b>Overall Length</b>	<b>2100mm</b>
<b>Overall Width</b>	<b>720mm</b>
<b>Weight</b>	<b>185kgs</b>

### NOTICE

- A. It is your responsibility as the operator of this piece of equipment to know what specific requirements, precautions and work hazards exist. You must read and understand all of the information contained in the user manual.
- B. The trencher is a small, operator propelled, chain-type trencher designed for the installation of lines that require a narrow shallow trench. It has more than enough power to trench through the toughest soils, however, because of its small size, low horse power and trench capacity, it is limited in what it is capable of doing. The job site, soil conditions, job specifications and operator experience may dictate that a different tool or method be used to do the job.
- C. The digging chain has a tendency to pull the trencher in the opposite direction you want to dig. For this reason, be sure that the digging teeth are not in contact with the ground or other objects while starting the engine and that the wheel lock device engages before lowering the digging bar into the ground. Be sure that you have a firm grip on the machine and are ready to control it when the digging bar comes in contact with the ground.
- D. The trencher has a tendency to “hop” or “buck” under certain conditions. This can be the result of certain soil conditions or buried objects that the trencher cannot cut through or lift to the surface. The trencher must be stopped and the object removed, or restarts the trench beyond the object.



---

---

## PART III: Operating the Trencher

---

---

It may be helpful to better familiarize yourself with the features of your Trencher before beginning the steps outlined in this chapter.

---

### CAUTION

- A. Read and understand all instructions, safety precautions, and/or warnings listed in “PART I: General Safety Rules” before operating the TRENCHER. If any doubt or question arises about the correct or safe method of performing anything found in this manual, please contact the dealers in your area.
  - B. Before loading and operating the Trencher, always wear protective gear, including safety goggles, hearing protection, tight-fitting gloves without draw strings or loose cuffs, and steel-toed shoes.
- 

### Assembling

#### Step 1: Assembling the handle system

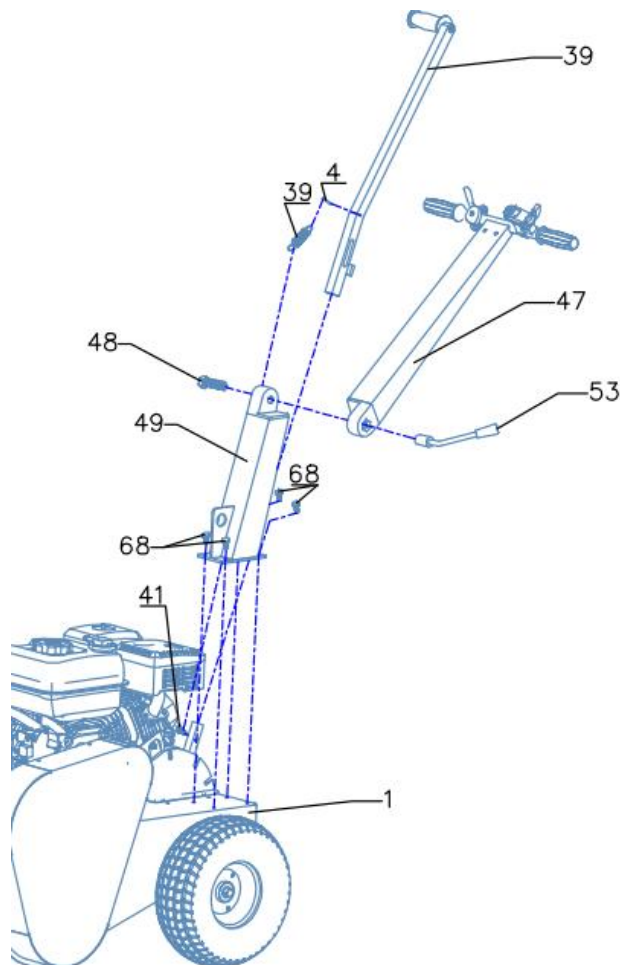

Ref.No.	Description	Ref.No.	Description
1	main frame	48	M16 bolt
4	cotter pin	49	lower handle
39	shift handle and spring	53	angle arm
41	M8 bolt	68	M8*20 hexagon bolt
47	upper handle		

- a. Secure lower handle(49) to the main frame(1) tightly.
- b. Assemble upper handle(47) to the lower handle(49), secure them with bolt(48) and angle arm(53) tightly.
- c. Plug shift arm(39) to the right place as figure shows and hold them with bolt(41) and spring(39), then secure another side of spring with pin(4) to the arm(39).

### Step 2: Assembling the blade system

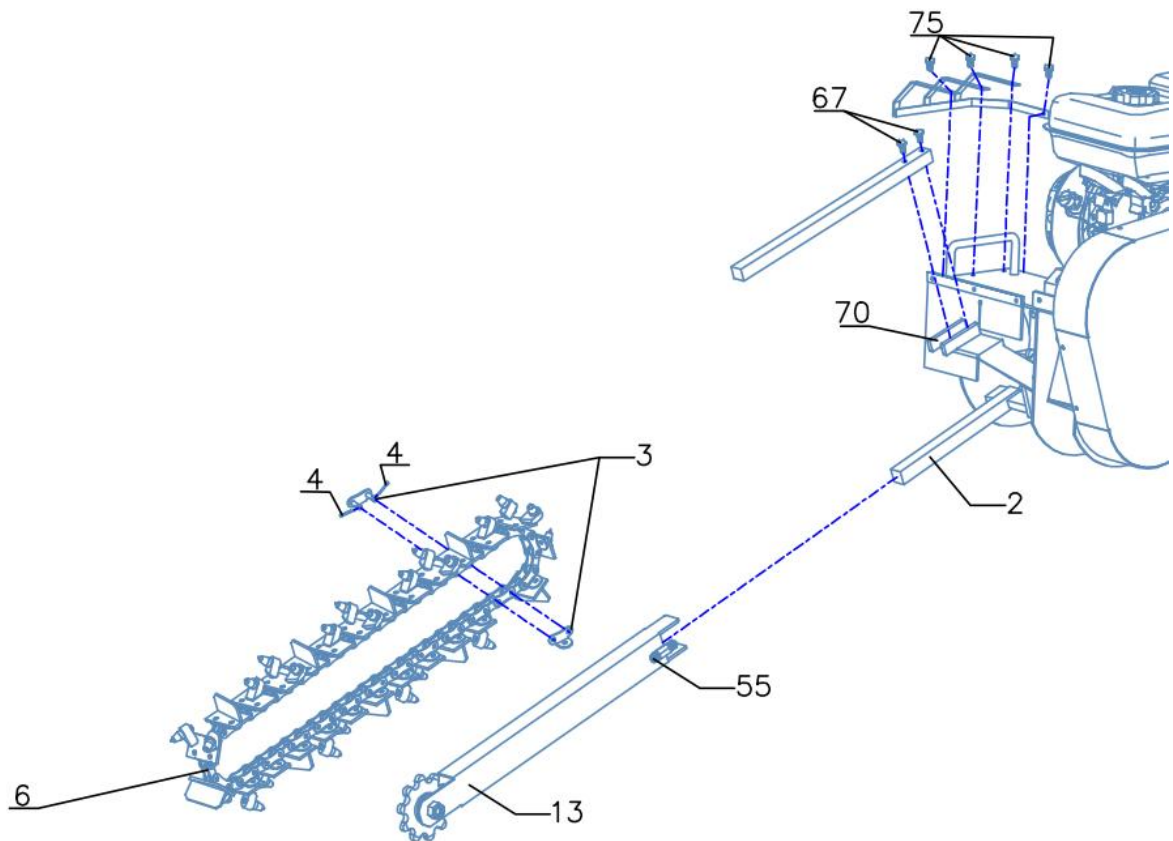

Ref.No.	Description	Ref.No.	Description
2	chain axle plate	55	M12 bolt
3	chain lock	67	M8*45 hexagon bolt
4	cotter pin	70	Pole fixation
6	chain	75	Side Protector
13	chain adapter		

- a. Plug chain adapter(13) to the chain axle(2);
- b. Hold the chain(6) around chain adapter(13) and axle(2), then secure two head of the chain with chain pin(4) and chain lock(3);
- c. Secure bolt(55) until the chain is tight enough;

## Starting

Be sure the depth control is in the “0” depth position and move both stop switches to the “ON” position. Always stand to the rear of the trencher, away from the side delivery auger and digging chain while starting the engine. Always start the trencher at the job site and allow it to warm up. While the machine is running, check that all controls are working properly before using.

### Start the engine following the procedures:

1. Make sure the fuel shut-off valve is in the “ON” position.
2. Move the choke control lever to the “CHOKE” position (should only be needed if the engine is cold).
3. Move the throttle control lever to the “FAST” position.
4. Recoil Start: Turn the Ignition Switch to the “On” position. Grasp the recoil starter handle and slowly pull until you feel resistance. Let the cord retract a little bit then pull the cord rapidly to start the engine. One or two pulls usually starts the engine.
5. Electric Start: Turn and hold the Key in the start position until Engine starts then let the Key return to run position.
6. Move the choke control lever (if used for cold engine) slowly back to the “RUN” position when the engine is running well.
7. If the Trencher has not been running (cold engine), warm up the engine by running the engine at half throttle for 3 to 4 minutes, then advance the engine throttle control to the maximum speed.

## Trenching

Be sure the digging chain is not turning when the engine is at an idle. Be sure the engine is off or at an idle before moving the trencher at the job site.

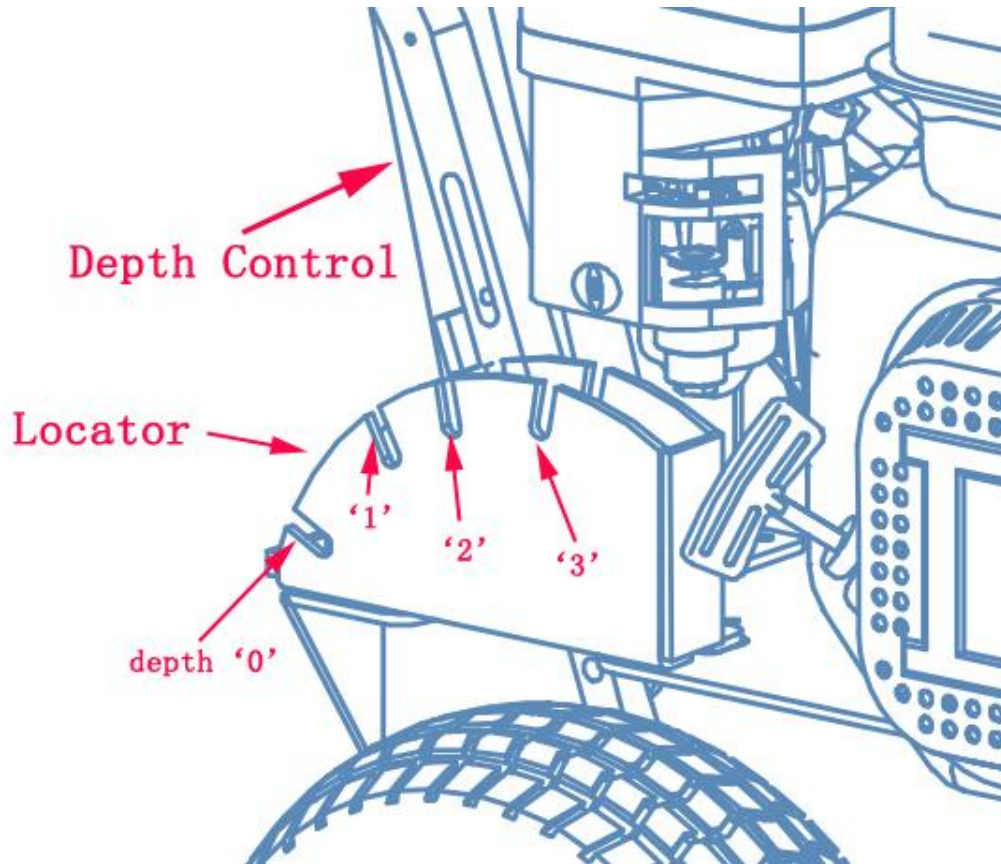

Figure 1

WORK POSITION	600mm TRENCHER
Depth "0"	0mm
Depth "1"	200mm
Depth "2"	400mm
Depth "3"	600mm

NOTE: All depths are approximate. Actual depth may vary depending upon soil conditions and trencher blade wear.

Also, soil conditions and operator experience will dictate actual trenching action and speed.

### A general description on how to trench:

1. With the engine running and at an idle and the depth control in the depth "0", apply downward pressure on the handle to raise the digging chain.
2. Lift the depth control handle and slowly move the lever forward into the desired depth notch.

3. Apply downward pressure to the handlebar so the digging chain is not in contact with the ground. Increase the engine speed and hold on to the handlebar with both hands. Slowly relieve the downward pressure on the handlebar allowing the digging chain to penetrate the soil until the chosen depth is reached.
4. Using an intermittent pulling action, pull the trencher toward you 4 to 6 inches then relax your pull, allowing the trencher to again reach the chosen depth.
5. Repeat this action until you have finished the job. The wheel lock will aid you in this operation by helping to hold the trencher in position until the next motion is started.

## Stopping

There are two stop switches on the trencher; one on the handle bar and one on the engine. Refer to the engine manual for the switch location on your trencher. The operator can turn the trencher off at any time by switching either stop switch to the “OFF” position. Both switches must be “ON” before the engine can start.

### Stopping the engine following the procedures:

1. Switching stop switch on handle.
2. Move the Throttle Lever to IDLE.
3. Recoil Start: Turn the Ignition Switch to the OFF position.
4. Electric Start: Turn the Key to the OFF position.

## When Blocked

If the Chain stops moving while digging trenches, the engine should be stopped, take out the muds or anything which stuck the chain, then restart the engine, and start digging again.

## Operator Safety

---

### **WARNING**

- A. All the rack and pinion should be greased before every use.
  - B. Always wear the proper clothing and protective gear. Eye and ear protection, hard hat, boots, gloves and dust masks are that may be required.
  - C. Keep hair, fingers, and all other body parts away from openings and moving parts. Always wear, long pants, boots, and gloves. Secure hair so it is above shoulder length.
  - D. Do not operate trencher indoors. Outdoor use only.
  - E. Do not operate trencher when tired, ill, or under the influence of alcohol, drugs, or medication.
  - F. Always assume the digging location contains underground utilities. Contact appropriate utility company to determine where electrical cables, gas lines, water lines, etc. are buried before operation.
  - G. Always use extreme caution while operating tool. Be sure of your footing and physical capabilities.
-

## Tools Safety

---

### CAUTION

- A. Inspect entire trencher before each use. Replace damaged or worn parts.
  - B. Check for fuel leaks and make sure all fasteners are in place and securely fastened.
  - C. Replace digging blades that are severely worn. Be sure the digging chain and engine is not moving.
- 

## Fuel Safety

---

### WARNING

- A. Refuel outdoors and where no sparks and flames.
  - B. Store fuel in a container approved for gasoline.
  - C. Do not smoke or allow smoking near fuel or the trencher or while using the trencher.
  - D. Clean up all fuel spills before starting engine.
  - E. Move at least 10 feet away from fueling site before starting engine.
  - F. Stop engine before removing fuel cap.
- 

## Digging Safety

---

### WARNING

- A. Be sure that the area is clear of potential hazards, such as pipes, rocks or other materials that could possibly entangle itself around the digging chain or cause unstable footing before using the trencher.
  - B. Keep others bystanders and helpers outside a 15 foot hazard zone from the trencher.  
Hold the trencher handle firmly with both hands.
  - C. Keep all your body and clothing away from the digging chain, auger and other moving parts.
  - D. Inspect the digging site. Soil, job specifications and operator experience may dictate that a different trencher or method be used to do the job.
  - E. Do not leave trenches open or unmarked.
-

## PART IV: Maintaining Your Trencher

Regular maintenance is the way to ensure the best performance and long life of your machine. Please refer to this manual and the engine manufacturer's user manual for maintenance procedures.

### Maintenance Safety

#### NOTICE

- A. Before performing any maintenance procedure or inspection, stop the engine, wait five minutes to allow all parts to cool.
- B. Disconnect the spark plug wire, keeping it away from the spark plug. Disconnect the Battery Terminals (Electric start only).
- C. Stop engine before removing fuel cap.
- D. Use only genuine replacement parts of the engine manufacturer.

### Regular Maintenance Checklist

Procedure	Before Use	Each	Every 3 Hours	Every 25 Hours	Every 100 Hours
Check engine oil level	Δ				
Check general equipment condition	Δ				
Check wedge for sharpness	Δ				
Check belts	Δ				
Check tire pressure				Δ	
Clean engine exterior and cooling				Δ	
Change Engine Oil	First time 5hours			Δ	
Replace air filter				Δ	
Replace spark plug					Δ

### Engine Service

Refer to the engine manufacturer's user manual for engine maintenance.

## Lubrication

---

### NOTICE

All Bearings of Trencher are sealed units and should have sufficient lubricant to last the life of your machine with normal use.

---

## Transportation and Storing

---

### NOTICE

- A. Always shut off the fuel valve and engine.
  - B. Always allow the engine to cool.
  - C. Store trencher and fuel where fuel vapors cannot reach sources of combustion like, water heaters, electric motors, switches, furnaces, etc.
  - D. Always secure this trencher with tie downs or similar restraints when transporting.
  - E. The trencher shall be stored in a manner that prevents it from falling, rolling or tipping over.
-

## PART V: Troubleshooting and Parts List

Most problems are easy to fix. Consult the Troubleshooting Table below for common problems and their solutions. If you continue to experience problems, contact the dealers in your area.

### **WARNING**

Before performing any maintenance procedure or inspection, stop the engine, wait five minutes to allow all parts to cool. Disconnect the spark plug wire, keeping it away from the spark plug.

### Troubleshooting Table

SYMPTOM	POSSIBLE CAUSE
<p><i>The engine won't start.</i></p> <p><i>(Please refer to the engine user manual for engine-specific procedures.)</i></p>	<p><i>Is the ignition switch in the "ON" position?</i></p> <p><i>Is the fuel shut-off valve on?</i></p> <p><i>Are you using fresh, clean gas? If the gas is old, change it. Use a fuel stabilizer if you keep gas longer than 30 days.</i></p> <p><i>Is the spark plug clean? If the spark plug is dirty or cracked, change it. If it's oily, leave it out, hold a rag over the plug hole and pull the recoil cord several times to blow out any oil in the cylinder, then wipe off the plug and reinsert it.</i></p>
<p><i>The engine lacks power or is not running smoothly.</i></p> <p><i>(Please refer to the engine user manual for engine-specific procedures.)</i></p>	<p><i>Check that the Throttle Lever is in the "Run" position.</i></p> <p><i>Is the air filter clean? If it's dirty, change it following the procedure in the engine manufacturer's owner's manual.</i></p> <p><i>Is the spark plug clean? If it's fouled or cracked, change it. If it's oily, leave it out, hold a rag over the plug hole and pull your recoil cord several times to blow out any oil in the cylinder, then wipe off the plug and reinsert it.</i></p> <p><i>Are you using fresh, clean unleaded gas? If it's old, change it. Use a fuel stabilizer if you keep gas longer than 30 days.</i></p> <p><i>Does your engine have the right amount of clean oil? If it's dirty, change it following the procedure in the engine manufacturer's owner's manual.</i></p> <p><i>Check the oil level and adjust as needed.</i></p>
<p><i>Engine smokes.</i></p> <p><i>(Please refer to the engine user manual for engine-specific</i></p>	<p><i>Check the oil level and adjust as needed.</i></p> <p><i>Check the air filter and clean or replace if needed.</i></p> <p><i>You may be using the wrong oil—too light for the temperature. Refer to your Engine Owner's Manual for detailed information.</i></p>

Part V: Troubleshooting and Parts List

---

*procedures.)*

*Clean the cooling fins if they're dirty.*

## Explosion View and Parts List

### 1. Chain System

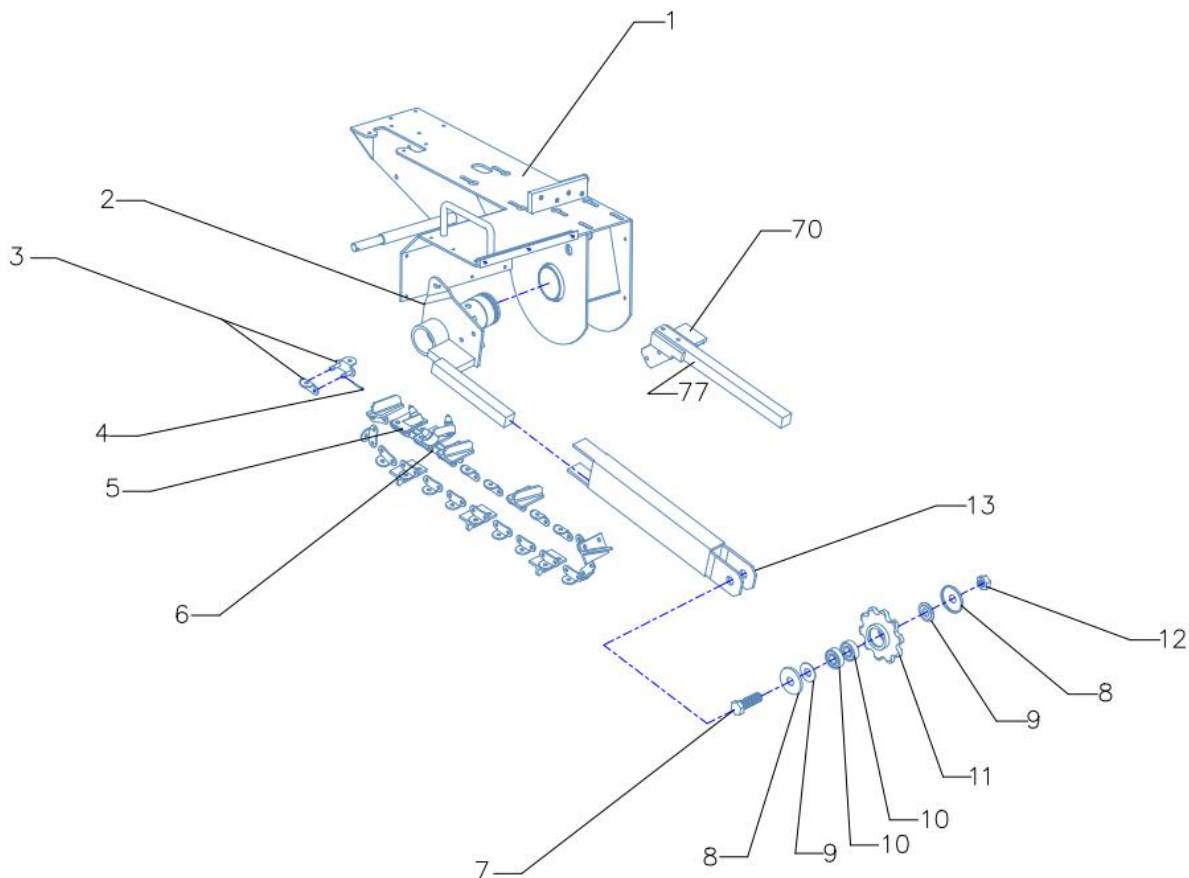

Ref.No.	Description	Ref.No.	Description
1	main frame	9	chain spacer
2	chain axle plate	10	6204 bearing
3	chain lock	11	front gear
4	cotter pin	12	M20 nut
5	blade	13	chain adapter
6	chain	70	Pole fixation
7	M20 bolt	77	Protect pole
8	gear cap		

## 2. Gear System

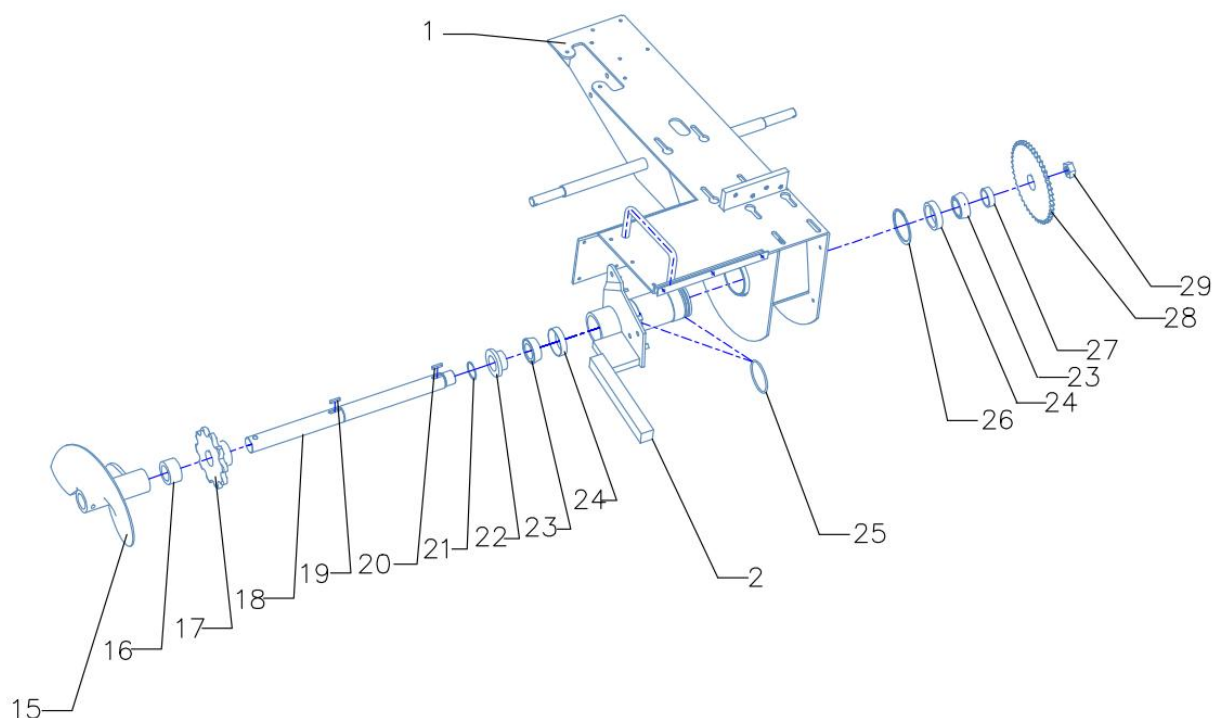

Ref.No.	Description	Ref.No.	Description
1	main frame	22	taper bearing flange spacer
2	chain axle plate	23	taper bearing upper part
15	ridge	24	taper bearing base
16	ridge spacer	25	70 seal
17	back gear	26	72 outer circlip
18	gear axle	27	taper bearing spacer
19	8*7 keyway	28	gear wheel
20	8*7 keyway	29	M30 screw nut
21	35 outer circlip		

### 3. Drive System

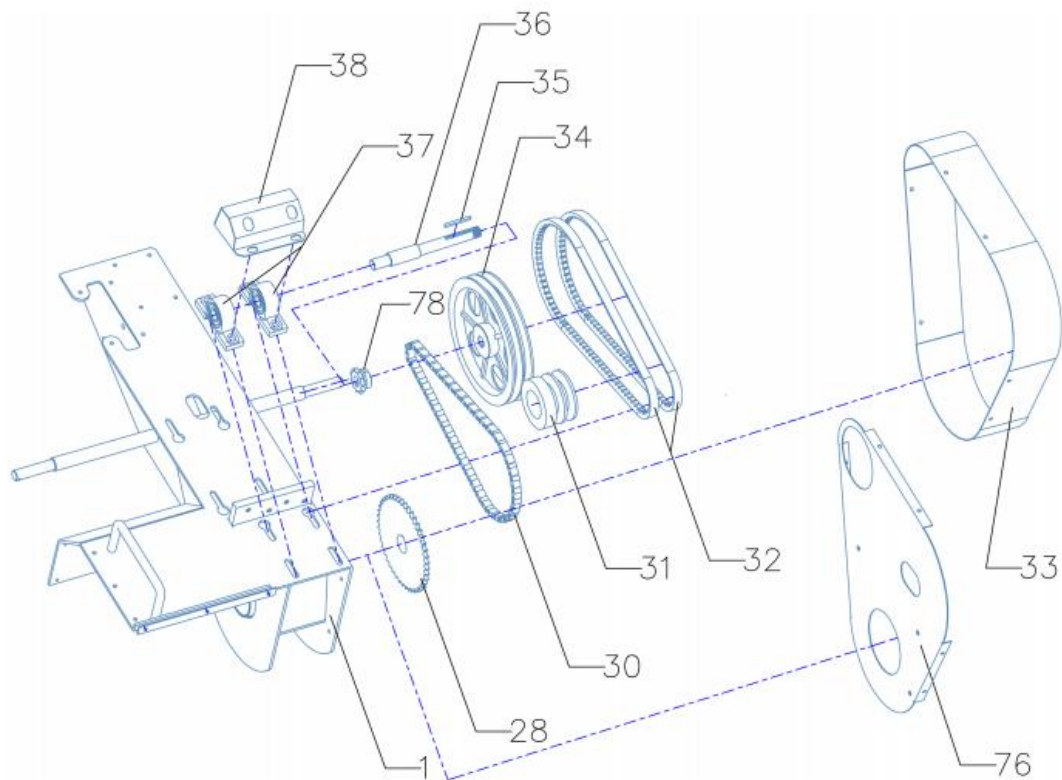

Ref.No.	Description	Ref.No.	Description
1	main frame	34	pulley
78	Drive Chain gear	35	5*5 keyway
28	gear wheel	36	pulley axle
30	drive chain	37	bearing
31	clutch	38	bearing cover
32	belt	76	Inner belt cover
33	belt cover		

## 4. Depth Control System

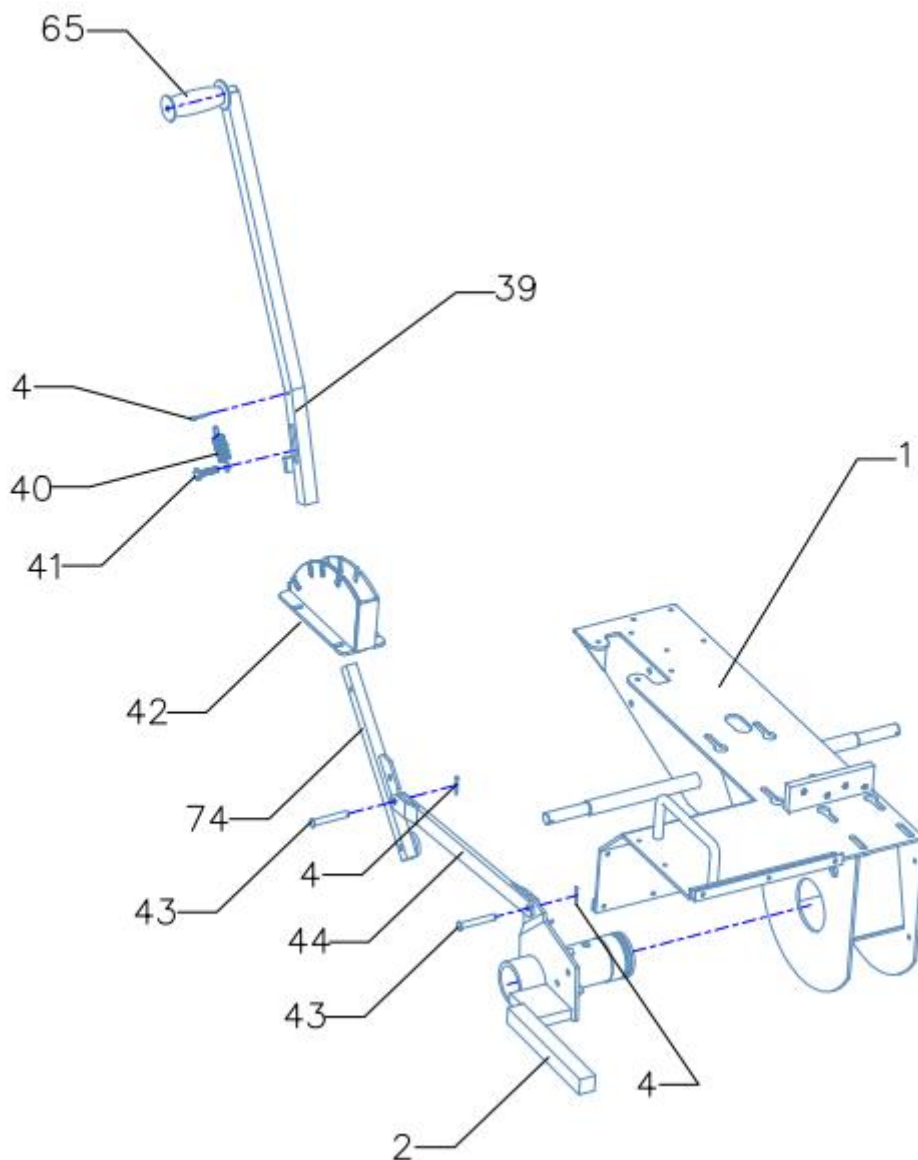

Ref.No.	Description	Ref.No.	Description
1	main frame	42	shift deck
2	chain axle plate	43	pin
4	cotter pin	44	shift rod
39	shift handle	65	Depth control handle
40	shift handle spring	74	Transfer pole
41	M8 bolt		

## 5. Main Frame

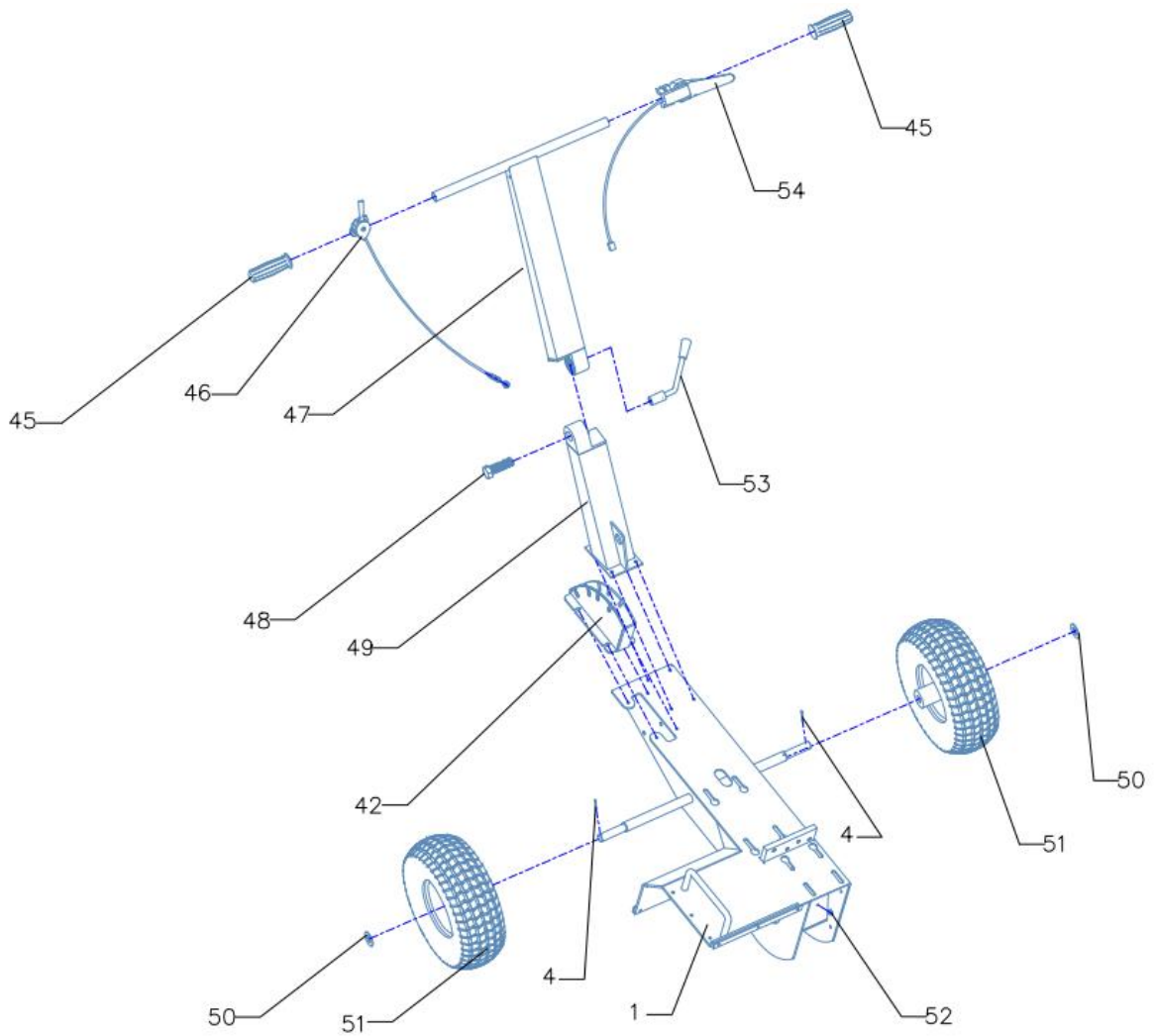

Ref.No.	Description	Ref.No.	Description
1	main frame	49	lower handle
4	cotter pin	50	20 washer
45	handle cover	51	wheel
46	throttle cable	52	butter bean
47	upper handle	53	angle arm
48	M16 bolt	54	flameout switch

## 6. Ratchet Assembly

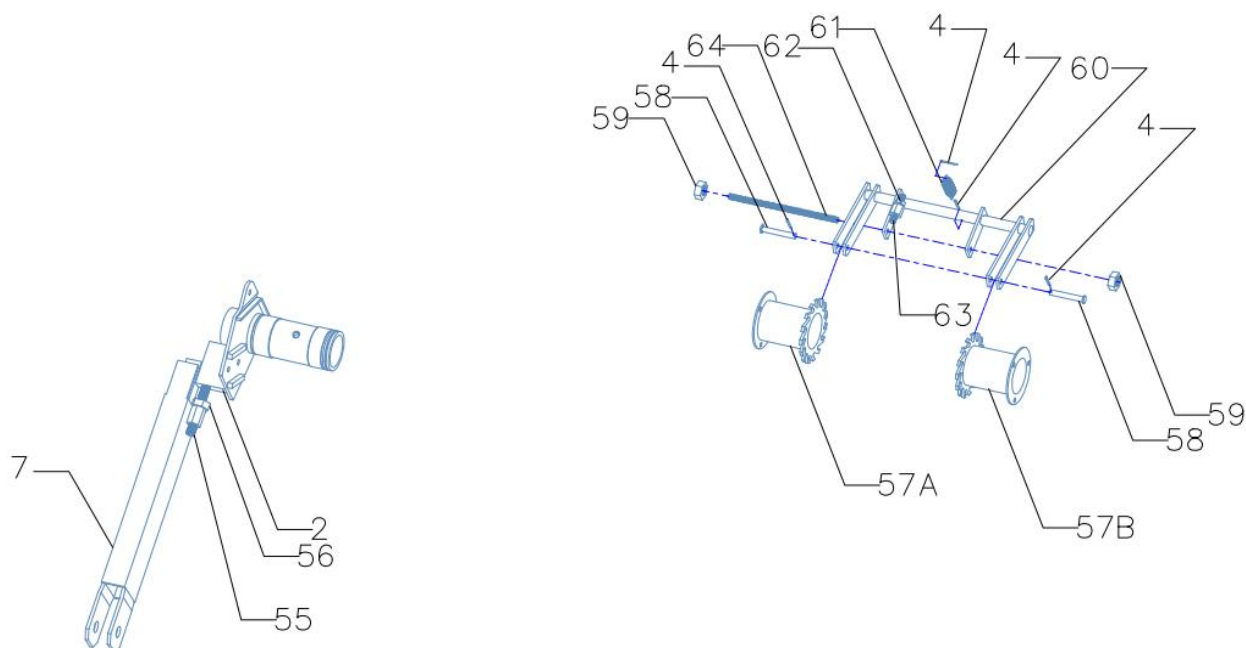

Ref.No.	Description	Ref.No.	Description
4	cotter pin	59	M10 nut
7	M20 bolt	60	halt frame
55	M12 bolt	61	spring
56	M12 nut	62	M10 nut
57	ratchet wheel	63	M10 bolt
58	pin	64	M10 headed screw

## Part List:

<b>Ref.No.</b>	<b>Description</b>	<b>Ref.No.</b>	<b>Description</b>
1	main frame	38	bearing cover
2	chain axle plate	39	shift handle
3	chain lock	40	shift handle spring
4	cotter pin	41	M8 bolt
5	blade	42	shift deck
6	Chain and blade rack	43	pin
7	M20 bolt	44	shift rod
8	gear cap	45	handle cover
9	chain spacer	46	throttle cable
10	6204 bearing	47	upper handle
11	front gear	48	M16 bolt
12	M20 nut	49	lower handle
13	chain adapter	50	20 washer
15	ridge	51	wheel
16	ridge spacer	52	butter bean
17	back gear	53	angle arm
18	gear axle	54	flameout switch
19	8*7 keyway	55	M12 bolt
20	8*7 keyway	56	M12 nut
21	35 outer circlip	57	ratchet wheel
22	taper bearing flange spacer	58	pin
23	taper bearing upper part	59	M10 nut
24	taper bearing base	60	halt frame
25	70 seal	61	spring
26	72 outer circlip	62	M10 nut
27	taper bearing spacer	63	M10 bolt
28	gear wheel	64	M10 headed screw
29	M30 screw nut	65	Depth control handle
30	drive chain	66	Tool kit
31	clutch	67	M8*45 hexagon bolt
32	belt	68	M8*20 hexagon bolt
33	belt cover	70	Pole fixation
34	pulley	74	Transfer pole
35	5*5 keyway	76	Inner belt cover
36	pulley axle	77	Protect pole
37	bearing	78	Drive chain gear